

## »BISON« D 1000 TECHNICAL DATA



### UNDER REALISTIC CONDITIONS AT THE AIRPORT:

With an aircraft tow tractor including 4-wheel-drive and equal weight distribution on both axes, on wet concrete (friction coefficient  $\mu=0.57$ ), 1% apron inclination, and aircraft engines running during pushback.

In case of different requirements please contact us for new calculations based on your specific operation conditions.

<b>OPERATION WEIGHTS</b>	+ 62,000 lbs   42,000 lbs   82,000 lbs   90,000 lbs   95,000 lbs   101,500 lbs max.
<b>MTOW</b>	+ 880,000 lbs
<b>DRAWBAR PULL INSTALLED</b>	+ 68,500 lbf



**FIND OUT MORE**  
»BISON« FAMILY

**MADE FOR YOUR MISSION**

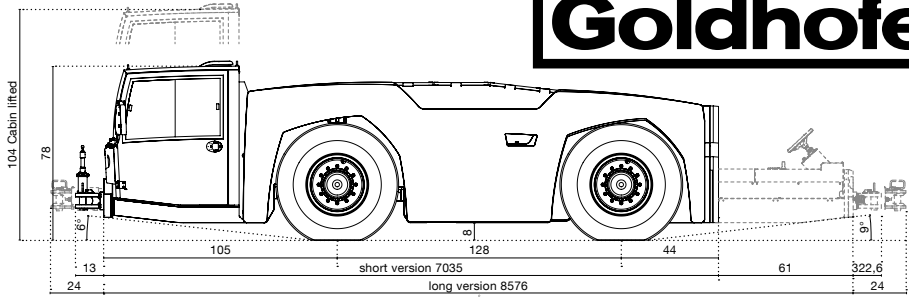
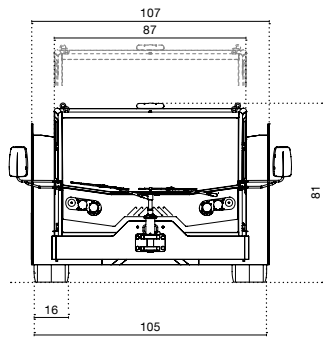

**DEUTZ ENGINE**

- + DEUTZ TCD 7.8 L6 268 hp at 2,200rpm
- + Fuel tank capacity max. 200l
- + EU Stage IIIA, IV or V
- + US EPA Tier 4



**TURNING RADIUS**

- + 244"
- + \* 250" long version

**TRANSMISSION**

- + 6 gears forward/3 reverse
- + Draw bar pull limiter dependent on selected aircraft type
- + ZF automatic full-power-shift transmission with integrated torque converter, manual and automatic gear-shifting mode

**AXLES**

- + Driven steering axles with planetary drives in the wheel hubs
- + Front and rear axles driven by full-power-shift transmission through joint shafts

**STEERING SYSTEM**

- + Standard 4-wheel steering
- + Front-wheel and crab steering (optional)
- + Emergency steering pump

**TIRES**

- + Front + rear 14.00x24

**BRAKES**

- + Fully hydraulic 3-circuit safety brakes
- + 2-circuit service brake
- + 1-circuit failsafe parking brake
- + Emergency parking-brake release by electrical emergency pump
- + Brake pad wear indicator

**HYDRAULIC SYSTEM**

- + Brakes and steering system
- + Cabin-lift and jacks

**ELECTRIC SYSTEM**

- + Alternator 28 V/100 A
- + Battery capacity 2x12 V/143 Ah
- + Engine starter 5 hp

**CABIN**

- CABLESS** + Full-width elevating, all-steel front cabin
- BASIC CABIN** + Comfortable driver's and passenger's seat with safety belts (third seat optional)
- + Adjustable steering column
- + Interior lights
- OPEN CAB** + Wiper-washer system for front
- OPTION** + Rear-view mirrors (1 inside, 2 outside)
- + Front tow-hitch mirror
- CLOSED CAB** + Lockable doors with sliding windows
- OPTION** + Cabin/windscreen ventilation and heating
- + Heated rear window with screen wiper



**OPTIONS EXAMPLES**

- + Cushioned tow hitch
- + Fully airconditioning system
- + Second passenger seat
- + Electrically adjustable and heated rearview mirror
- + Rear-view camera
- + Auxiliary heater Webasto with timer
- + Central lubrication system
- + Remote Control
- + 4 integrated hydraulic jacks

**GOLDHOFER AIRPORT TECHNOLOGY**

Location: Donaustrasse 95, 87700 Memmingen/Germany  
 Location: Parkstrasse 19-21, 73760 Ostfildern/Germany  
 Web: www.goldhofer.com, E-Mail: info@goldhofer.com

**FLITELINE, LLC**

Location: 7401 Riviera Boulevard, Miramar, FL 33023, USA  
 Telephone: +1 954 433 5617, Fax: +1 954 433 5445  
 Web: www.flitelineusa.com, E-Mail: info@flitelineusa.com

**SALES**

Telephone: +49 8331 15-343  
 E-Mail: sales-airporttechnology@goldhofer.com

**SERVICE AND SPARE PARTS**

Telephone: +49 8331 962 99 99, Fax: +49 8331 15-247  
 E-Mail: service-airporttechnology@goldhofer.com

**MADE FOR YOUR MISSION**

Subject to technical progress and regulations in force, we reserve the right to change the above specifications. Data +/- 3%.

02-BISON<sup>®</sup> D 1000 | 10/2019-EN | IMPERIAL