

»BISON« D 370 TECHNICAL DATA



UNDER REALISTIC CONDITIONS AT THE AIRPORT:

With an aircraft tow tractor including 4-wheel-drive and equal weight distribution on both axes, on wet concrete (friction coefficient $\mu=0.57$), 1% apron inclination, and aircraft engines running during pushback.

In case of different requirements please contact us for new calculations based on your specific operation conditions.

OPERATION WEIGHTS	+ 19,800 lbs 22,000 lbs 24,000 lbs 26,000 lbs 30,000 lbs 37,000 lbs max.
MTOW	+ 220,000 lbs
DRAWBAR PULL INSTALLED	+ 23,6000 lbf



FIND OUT MORE
»BISON« FAMILY

MADE FOR YOUR MISSION

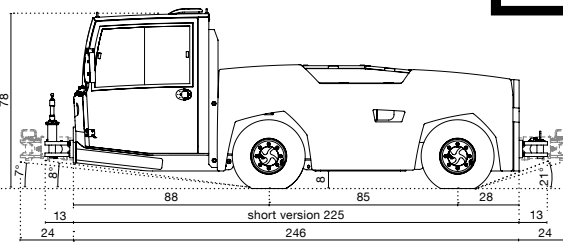
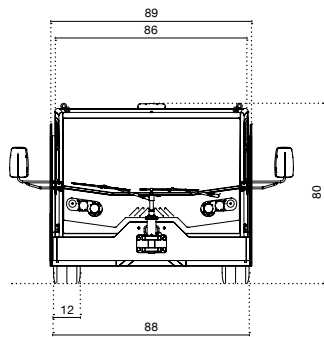

DEUTZ ENGINE

- + DEUTZ TCD 3.6 L4 100 hp at 2,300rpm
- + Fuel tank capacity max. 135l
- + EU Stage IIIA, IV or V
- + US EPA Tier 4



TURNING RADIUS

- + 179"

TRANSMISSION

- + 3 gears forward/3 reverse
- + Draw bar pull limiter dependent on selected aircraft type
- + ZF automatic full-power-shift transmission with integrated torque converter, manual and automatic gear-shifting mode

AXLES

- + Driven steering axles with planetary drives in the wheel hubs
- + Front and rear axles driven by full-power-shift transmission through joint shafts

STEERING SYSTEM

- + Standard 4-wheel steering
- + Front-wheel and crab steering (optional)
- + Emergency steering pump

TIRES

- + Front + rear 245/70R 17.5

BRAKES

- + Fully hydraulic 3-circuit safety internal brake system
- + 2-circuit service brake
- + 1-circuit failsafe parking brake
- + Emergency parking-brake release by electrical emergency pump

HYDRAULIC SYSTEM

- + Brakes and steering system

ELECTRIC SYSTEM

- + Alternator 28 V/100 A
- + Battery capacity 2x12 V/88 Ah
- + Engine starter 5 hp

CABIN

- CABLESS + Full-width, all-steel front cabin
- BASIC CABIN + Comfortable driver's and passenger's seat with safety belts (third seat optional)
- + Adjustable steering column
- + Interior lights
- OPEN CAB + Wiper-washer system for front
- OPTION + Rear-view mirrors (1 inside, 2 outside)
- + Front tow-hitch mirror
- CLOSED CAB + Lockable doors with sliding windows
- OPTION + Cabin/windscreen ventilation and heating
- + Heated rear window with screen wiper



OPTIONS EXAMPLES

- + Cushioned tow hitch
- + Fully airconditioning system
- + Second passenger seat
- + Electrically adjustable and heated rearview mirror
- + Rear-view camera
- + Auxiliary heater Webasto with timer
- + Central lubrication system
- + Remote control

GOLDHOFER AIRPORT TECHNOLOGY

Location: Donaustrasse 95, 87700 Memmingen/Germany
 Location: Parkstrasse 19-21, 73760 Ostfildern/Germany
 Web: www.goldhofer.com, E-Mail: info@goldhofer.com

FLITELINE, LLC

Location: 7401 Riviera Boulevard, Miramar, FL 33023, USA
 Telephone: +1 954 433 5617, Fax: +1 954 433 5445
 Web: www.flitelineusa.com, E-Mail: info@flitelineusa.com

SALES

Telephone: +49 8331 15-343
 E-Mail: sales-airporttechnology@goldhofer.com

SERVICE AND SPARE PARTS

Telephone: +49 8331 962 99 99, Fax: +49 8331 15-247
 E-Mail: service-airporttechnology@goldhofer.com

MADE FOR YOUR MISSION