

## »BISON« E 370 TECHNICAL DATA



### UNDER REALISTIC CONDITIONS AT THE AIRPORT:

With an aircraft tow tractor including 4-wheel-drive and equal weight distribution on both axes, on wet concrete (friction coefficient  $\mu=0.57$ ), 1% apron inclination, and aircraft engines running during pushback.

In case of different requirements please contact us for new calculations based on your specific operation conditions.

<b>OPERATION WEIGHTS</b>	+ 19,800 lbs   22,000 lbs   24,000 lbs   26,000 lbs   30,000 lbs   37,000 lbs max.
<b>MTOW</b>	+ 220,000 lbs
<b>DRAWBAR PULL INSTALLED</b>	+ 23,6000 lbf



**FIND OUT MORE**  
»BISON« FAMILY

**MADE FOR YOUR MISSION**

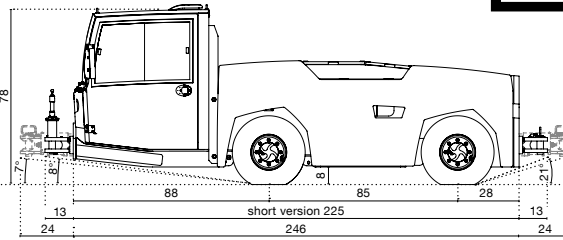
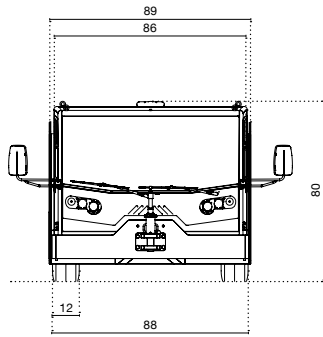

**317 ft lb | 107 hp**



**400 V LITHIUM-ION BATTERY**

Maximum installed Battery capacity 141 hp h (3x47 hp h)  
Integrated charging system power of 59 hp



**TURNING RADIUS  
TRANSMISSION**

- + 179"
- + 3 gears forward/3 reverse
- + Draw bar pull limiter dependent on selected aircraft type
- + ZF automatic full-power-shift transmission with integrated torque converter, manual and automatic gear-shifting mode

**AXLES**

- + Driven steering axles with planetary drives in the wheel hubs
- + Front and rear axles driven by full-power-shift transmission through joint shafts

**STEERING SYSTEM**

- + Standard 4-wheel steering
- + Front-wheel and crab steering (optional)
- + Emergency steering pump

**TIRES**

- + Front + rear 245/70R 17.5

**BRAKES**

- + Fully hydraulic 2-circuit safety internal brake system
- + 1-circuit failsafe parking brake
- + Emergency parking-brake release by electrical emergency pump

**HYDRAULIC SYSTEM**

- + Brakes and steering system

**CABIN**

- CABLESS + Full-width, all-steel front cabin
- BASIC CABIN + Comfortable driver's and passenger's seat with safety belts (third seat optional)
- + Adjustable steering column
- + Interior lights
- OPEN CAB + Wiper-washer system for front
- OPTION + Rear-view mirrors (1 inside, 2 outside)
- + Front tow-hitch mirror
- CLOSED CAB + Lockable doors with sliding windows
- OPTION + Cabin/windscreen ventilation and heating
- + Heated rear window with screen wiper



**OPTIONS  
EXAMPLES**

- + Cushioned tow hitch
- + Fully airconditioning system
- + Second passenger seat
- + Electrically adjustable and heated rearview mirror
- + Rear-view camera
- + Auxiliary heater Webasto with timer
- + Central lubrication system
- + Remote control

**GOLDHOFER AIRPORT TECHNOLOGY**

Location: Donaustrasse 95, 87700 Memmingen/Germany  
Location: Parkstrasse 19-21, 73760 Ostfildern/Germany  
Web: www.goldhofer.com, E-Mail: info@goldhofer.com

**FLITELINE, LLC**

Location: 7401 Riviera Boulevard, Miramar, FL 33023, USA  
Telephone: +1 954 433 5617, Fax: +1 954 433 5445  
Web: www.flitelineusa.com, E-Mail: info@flitelineusa.com

**SALES**

Telephone: +49 8331 15-343  
E-Mail: sales-airporttechnology@goldhofer.com

**SERVICE AND SPARE PARTS**

Telephone: +49 8331 962 99 99, Fax: +49 8331 15-247  
E-Mail: service-airporttechnology@goldhofer.com



Subject to technical progress and regulations in force, we reserve the right to change the above specifications. Data +/- 3%. 02-BISON® E 370 | 10/2019-EN | IMPERIAL