

»BISON« E 620 TECHNICAL DATA



UNDER REALISTIC CONDITIONS AT THE AIRPORT:

With an aircraft tow tractor including 4-wheel-drive and equal weight distribution on both axes, on wet concrete (friction coefficient $\mu=0.57$), 1% apron inclination, and aircraft engines running during pushback.

In case of different requirements please contact us for new calculations based on your specific operation conditions.

OPERATION WEIGHTS	+ 37,500 lbs 46,000 lbs 57,000 lbs 62,000 lbs max.
MTOW	+ 550,000 lbs
DRAWBAR PULL INSTALLED	+ 46,000 lbf



FIND OUT MORE
»BISON« FAMILY

MADE FOR YOUR MISSION

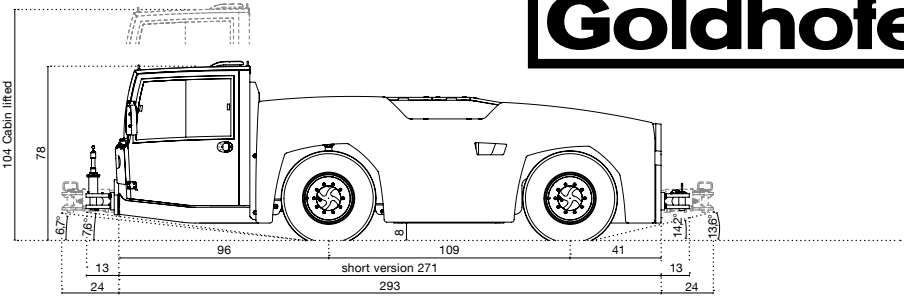
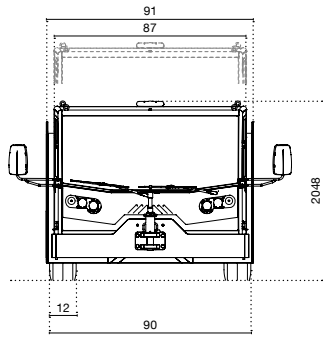

Goldhofer

449 ft lb | 154 hp

Maximum installed Battery capacity 188 hp h (4x47 hp h)
Integrated charging system power of 59 hp



400 V LITHIUM-ION BATTERY



TURNING RADIUS TRANSMISSION

+ 237"

+ 6 gears forward/3 reverse
+ Draw bar pull limiter dependent on selected aircraft type

+ ZF automatic full-power-shift transmission with integrated torque converter, manual and automatic gear-shifting mode

AXLES

+ Driven steering axles with planetary drives in the wheel hubs

+ Front and rear axles driven by full-power-shift transmission through joint shafts

STEERING SYSTEM

+ Standard 4-wheel steering
+ Front-wheel and crab steering (optional)

+ Emergency steering pump

TIRES

+ Front + rear 310/80R 22.5

BRAKES

+ Fully hydraulic 2-circuit safety internal brake system
+ 1-circuit failsafe parking brake

+ Emergency parking-brake release by electrical emergency pump

HYDRAULIC SYSTEM

+ Brakes and steering system

+ Cabin-lift and jacks

CABIN

CABLESS + Full-width elevating, all-steel front cabin

BASIC CABIN + Comfortable driver's and passenger's seat with safety belts (third seat optional)
+ Adjustable steering column
+ Interior lights

OPEN CAB OPTION + Wiper-washer system for front
+ Rear-view mirrors (1 inside, 2 outside)
+ Front tow-hitch mirror

CLOSED CAB OPTION + Lockable doors with sliding windows
+ Cabin/windscreen ventilation and heating
+ Heated rear window with screen wiper



OPTIONS EXAMPLES

+ Cushioned tow hitch
+ Fully airconditioning system
+ Second passenger seat
+ Electrically adjustable and heated rearview mirror

+ Rear-view camera
+ Auxiliary heater Webasto with timer
+ Central lubrication system
+ Remote Control
+ 4 integrated hydraulic jacks

GOLDHOFER AIRPORT TECHNOLOGY

Location: Donaustrasse 95, 87700 Memmingen/Germany
Location: Parkstrasse 19-21, 73760 Ostfildern/Germany
Web: www.goldhofer.com, E-Mail: info@goldhofer.com

FLITELINE, LLC

Location: 7401 Riviera Boulevard, Miramar, FL 33023, USA
Telephone: +1 954 433 5617, Fax: +1 954 433 5445
Web: www.flitelineusa.com, E-Mail: info@flitelineusa.com

SALES

Telephone: +49 8331 15-343
E-Mail: sales-airporttechnology@goldhofer.com

SERVICE AND SPARE PARTS

Telephone: +49 8331 962 99 99, Fax: +49 8331 15-247
E-Mail: service-airporttechnology@goldhofer.com

MADE FOR YOUR MISSION