

F396 TECHNICAL DATA



UNDER REALISTIC CONDITIONS AT THE AIRPORT:

With an aircraft tow tractor including 4-wheel-drive and equal weight distribution on both axles, on wet concrete (friction coefficient $\mu=0,57$), 1% apron inclination, and aircraft engines running during pushback.

In case of different requirements please contact us for new calculations based on your specific operation conditions.

VEHICLE	F396E	F396C	F396P
OPERATION WEIGHTS	+ 101,400-132,280lbs max.	+ 101,400-154,330lbs max.	+ 110,230-154,320lbs max.
MTOW MAX.	+ 881,000 lbs	+ 1,323,000 lbs	+ 1,323,000 lbs
DRAWBAR PULL INSTALLED	+ 83,180 lbf	+ 94,420 lbf	+ 103,412 lbf



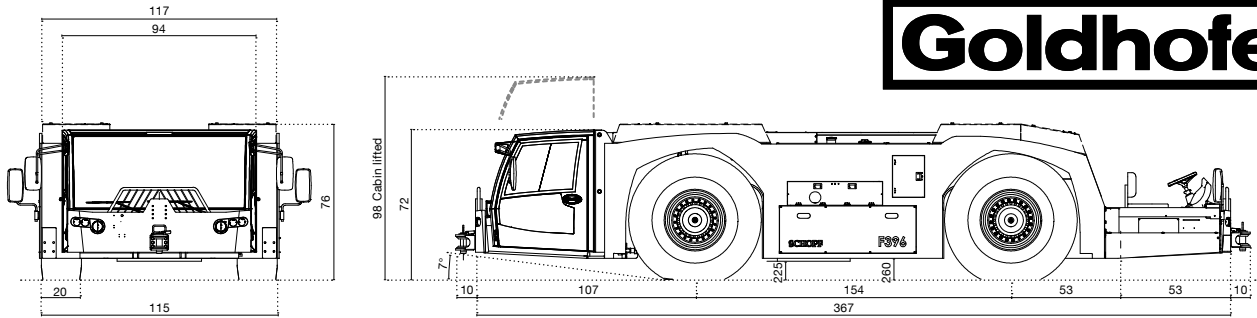

**DIESEL
DEUTZ TCD**

F396E

EU Stage IIIA, IIIB
US EPA Tier 3, 4i

2013 L06, integrated EMR
272 hp at 2,300 rpm,
774 lbf at 1,200 rpm

7.8 L06, integrated EMR
272 hp at 2,200 rpm,
774 lbf at 1,450 rpm

F396C

EU Stage IIIA, IV
US EPA Tier 3, 4f

2015 V06, integrated EMR
408 hp at 2,100 rpm,
1,475 lbf at 1,300 rpm

12.0 V06, integrated EMR
408 hp at 2,100 rpm,
1,475 lbf at 1,400 rpm

F396P

EU Stage IIIA, IIIB
US EPA Tier 3, 4i

2015 V06, integrated EMR
448 hp at 2,100 rpm,
1,468 lbf at 1,300 rpm

12.0 V06, integrated EMR
448 hp at 2,100 rpm,
1,475 lbf at 1,400 rpm



TURNING RADIUS

+ 272"

TRANSMISSION

+ 6 gears forward/3 reverse	+ ZF ergopower
+ Jerk-free, automatic full-power shift with integrated torque converter	F396E: WG210 F396C/P: WG310

AXLES

+ Driven steering axles with planetary drives in the wheel hubs	+ Front and rear axles driven by full-power-shift transmission through joint shafts
---	---

STEERING SYSTEM

+ Electro-hydraulic steering	+ 4 wheel steering, coordinated
+ Front wheel steering	+ Crab steering
+ Rear wheel steering	

TIRES

+ Front + rear 16.00/18.00x25

BRAKES

+ Fully hydraulic 3-circuit safety disk-brake system with accumulator back-up	+ 1-circuit failsafe parking/emergency brake
+ 2-circuit service brake	+ Electrically driven emergency pump

HYDRAULIC SYSTEM

+ Brakes and steering system	+ Cabin-lift and jacks
------------------------------	------------------------

ELECTRIC SYSTEM

+ Alternator 28 V/80 A	+ Battery capacity
+ System 24 V	F396E: 2x12 V/143 Ah
+ Engine starter	F396C/P: 2x12 V/200 Ah
F396E: 4,0 kW	
F396C/P: 6,5 kW	

CABIN

+ Full-width elevating, all-steel front cabin	+ Two adjustable suspension seats with safety belts
+ 2 headlights, low and high beam	
+ Lockable doors with sliding windows	



**OPTION
EXAMPLES**

+ Hydropneumatic suspension	+ Heating system
+ Rear driver's stand	+ Airconditioning
+ Rear driver's cabin	+ Cabin-roof light barrier or antenna sensor
+ GPU platform	+ 4 integrated hydraulic jacks
+ Various tow hitches	+ Rear-view video camera
+ Winterization-kits	

GOLDHOFER AIRPORT TECHNOLOGY

Location: Donaustasse 95, 87700 Memmingen/Germany
Location: Parkstrasse 19-21, 73760 Ostfildern/Germany
Web: www.goldhofer.com, E-Mail: info@goldhofer.com

FLITELINE, LLC

Location: 7401 Riviera Boulevard, Miramar, FL 33023, USA
Telephone: +1 954 433 5617, Fax: +1 954 433 5445
Web: www.flitelineusa.com, E-Mail: info@flitelineusa.com

SALES

Telephone: +49 8331 15-343
E-Mail: sales-airporttechnology@goldhofer.com

SERVICE AND SPARE PARTS

Telephone: +49 8331 962 99 99, Fax: +49 8331 15-247
E-Mail: service-airporttechnology@goldhofer.com

MADE FOR YOUR MISSION